

Teilauszug

Auszugsweg $\leq 80\%$ der Schienenlänge

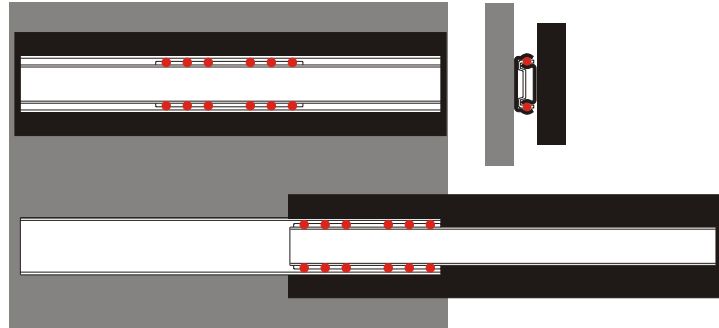

Vollauszug "Classic"

Auszugsweg ca. 80% bis $\geq 100\%$

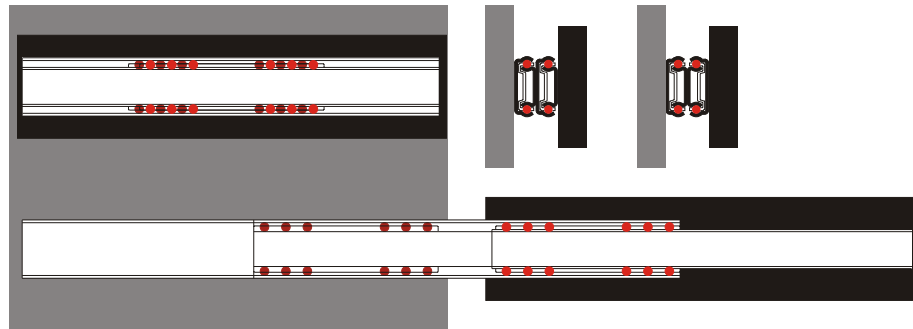

Vollauszug "Compact"

Auszugsweg ca. 80% bis $\geq 100\%$

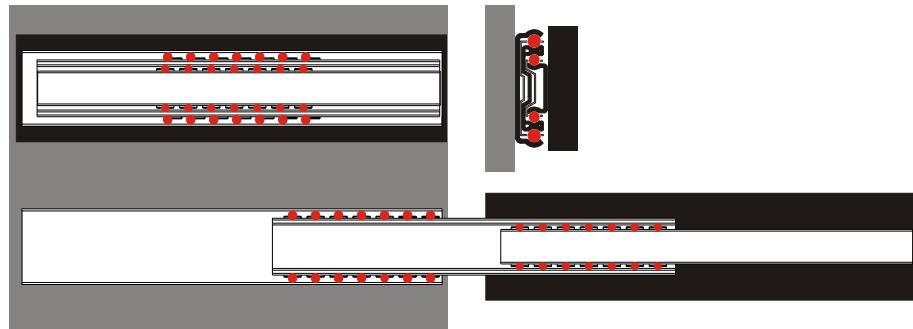

Läuferführung

Verfahrweg innerhalb der Schienenlänge

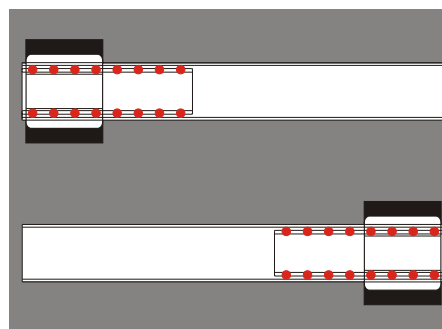

Basisprofile - Teilauszüge

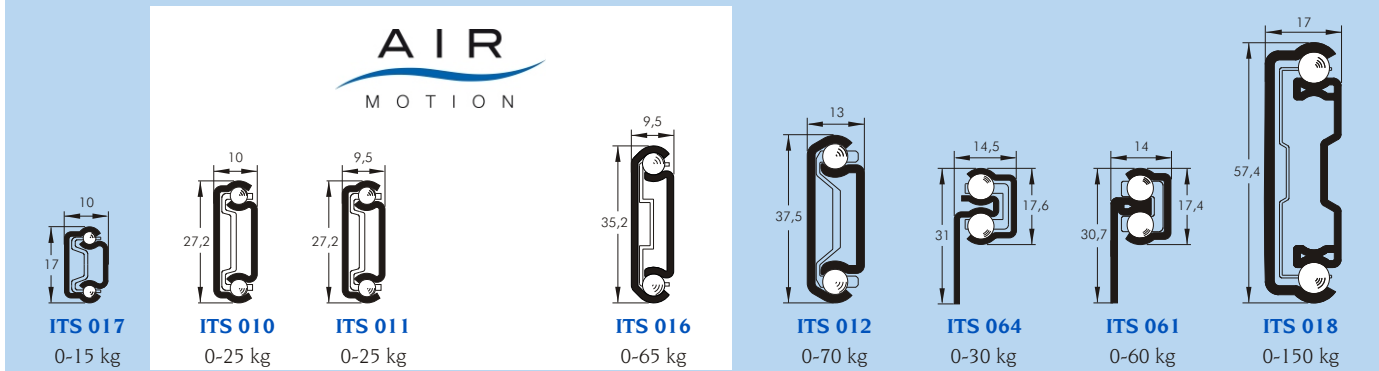

Edelstahl

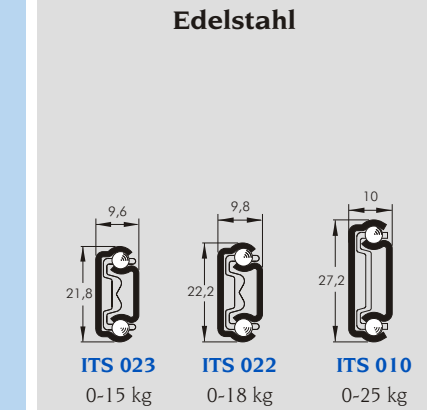

Sonderformen Beispiele

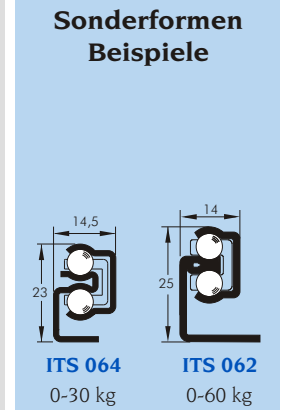

Basisprofile - Vollauszüge "Classic"

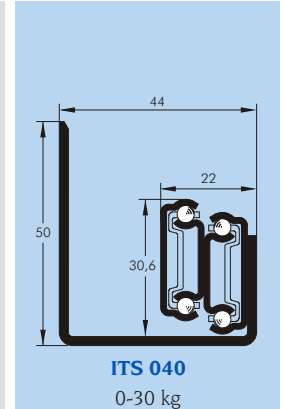
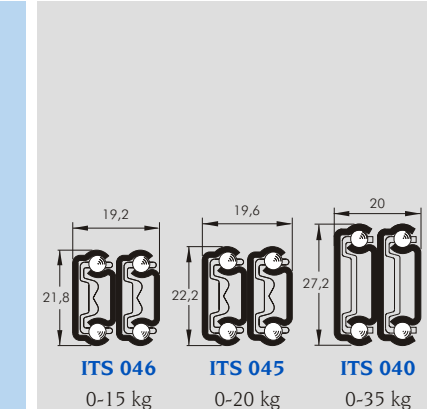
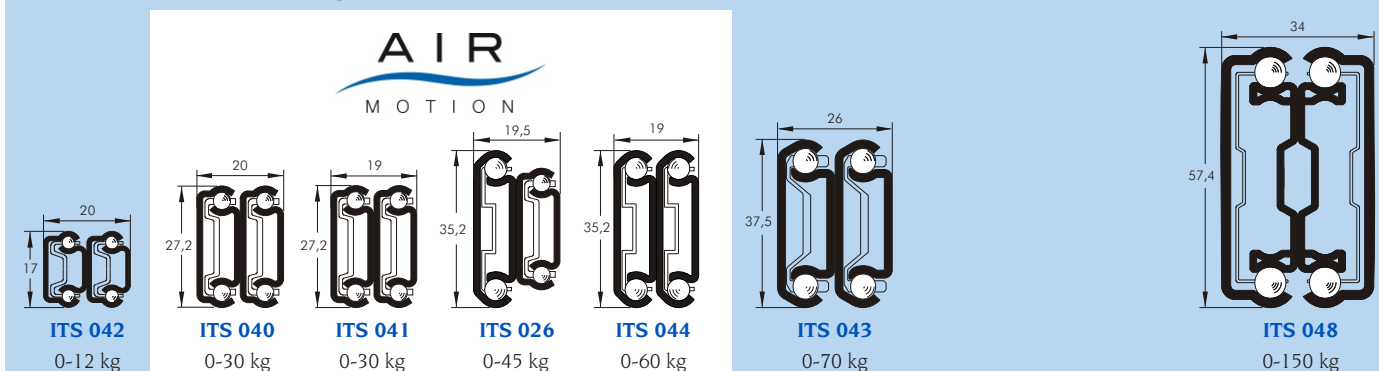

Basisprofile - Vollauszüge "Compact"

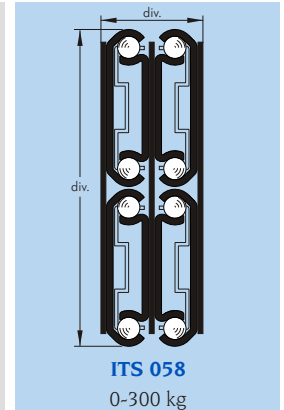
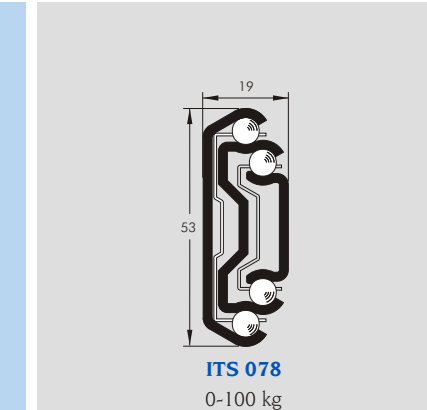
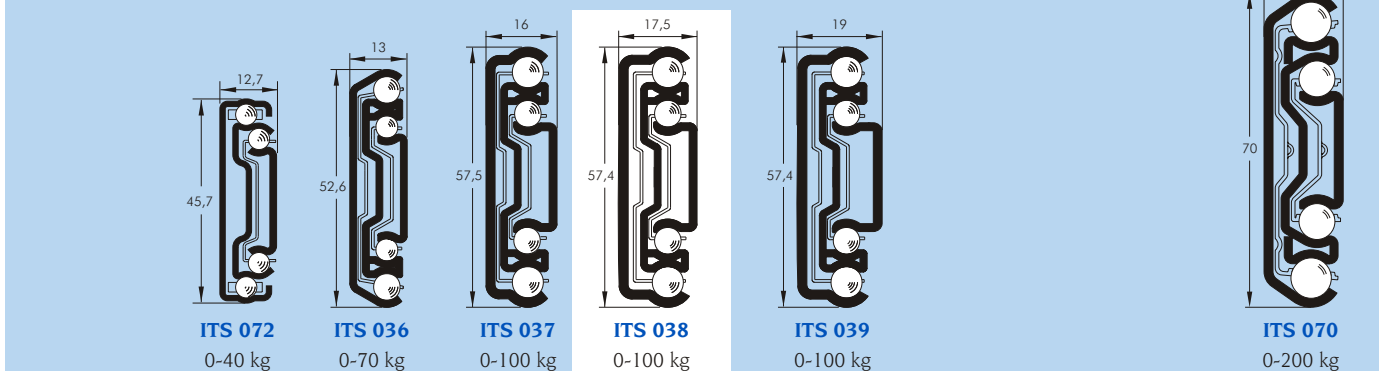

Basisprofile - Läuferführungen

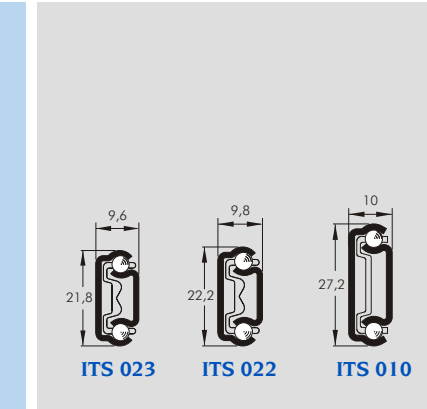
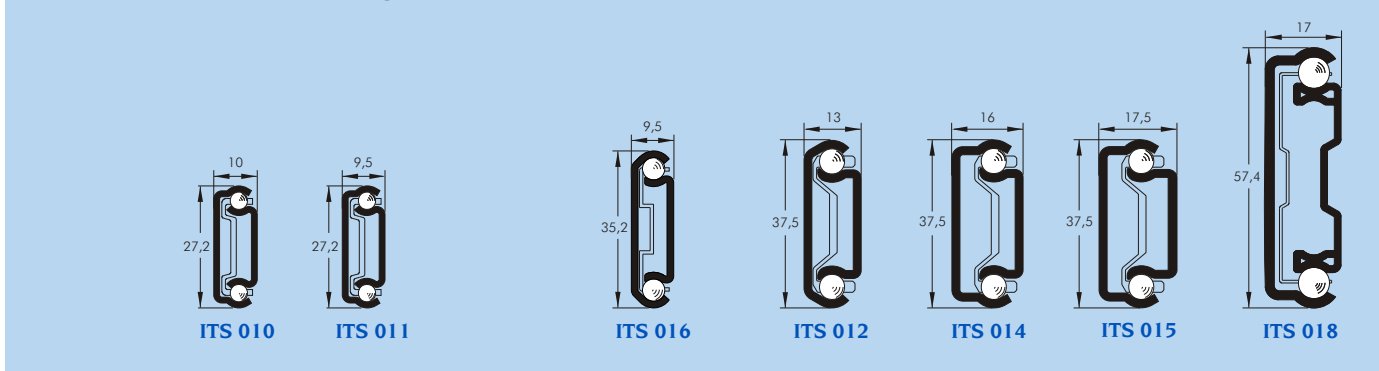

Hinweis:
Die angegebenen Lastwerte sind Richtwerte für paarweise vertikal montierte Führungen.
Die Maße sind in mm angegeben.